

3 PHASE 208VAC
DISABLED WHEN EMO TRIPPED

EMERGENCY OFF CIRCUIT (EMO)

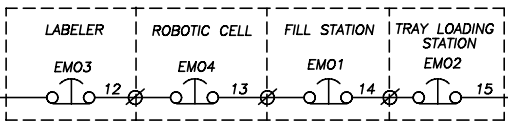

PB1
RESET

MC1
0001

TS1
TOUCH SCREEN
OMRON
NS10-TV01B-V2

ETHERNET HUB
MOXA
EDS-208

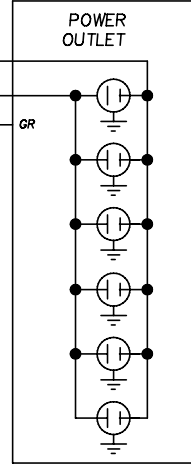

TERMINAL LAYOUT

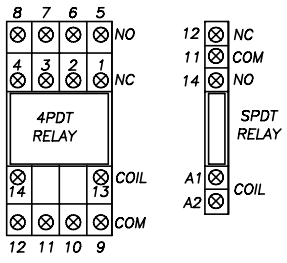

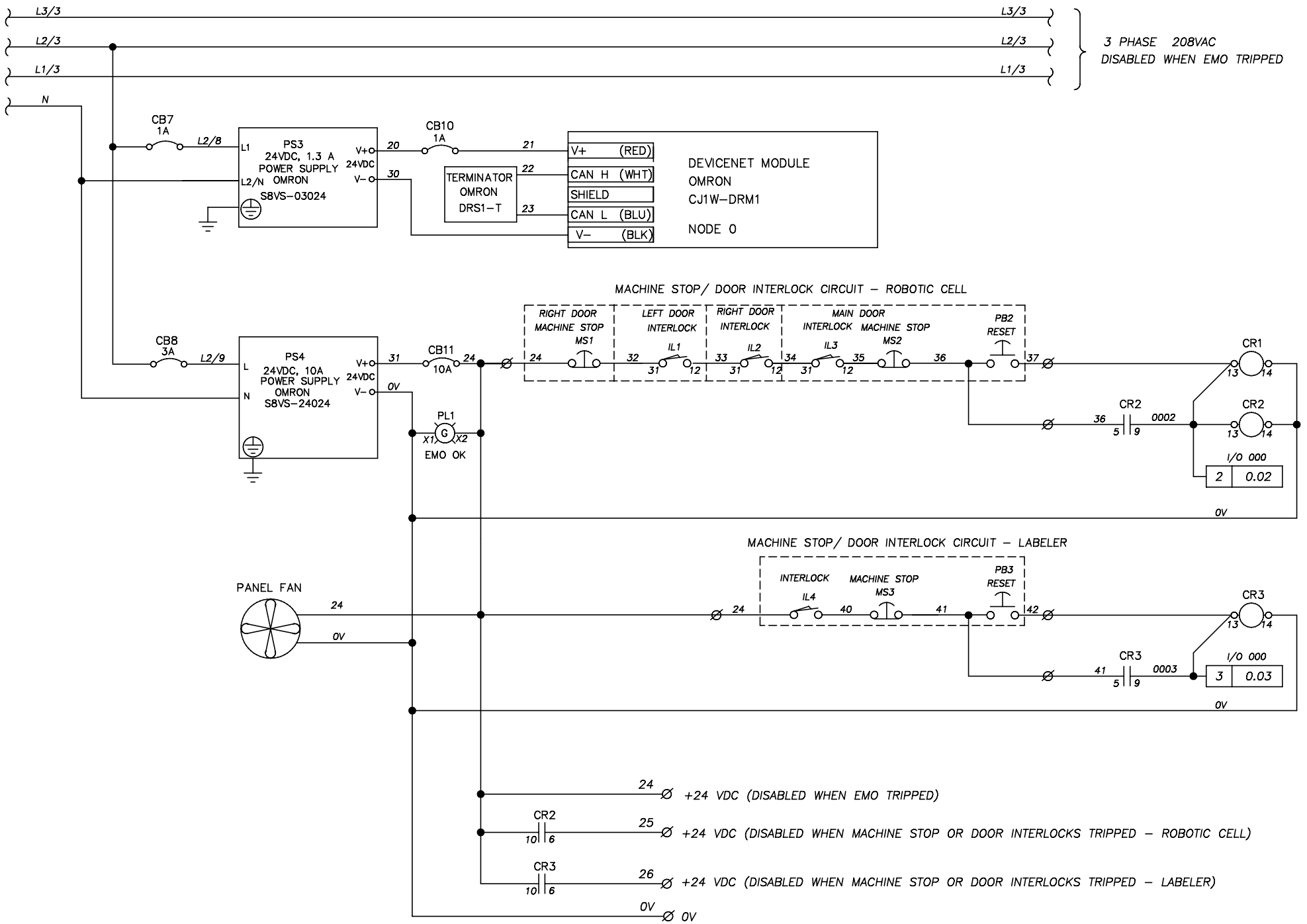

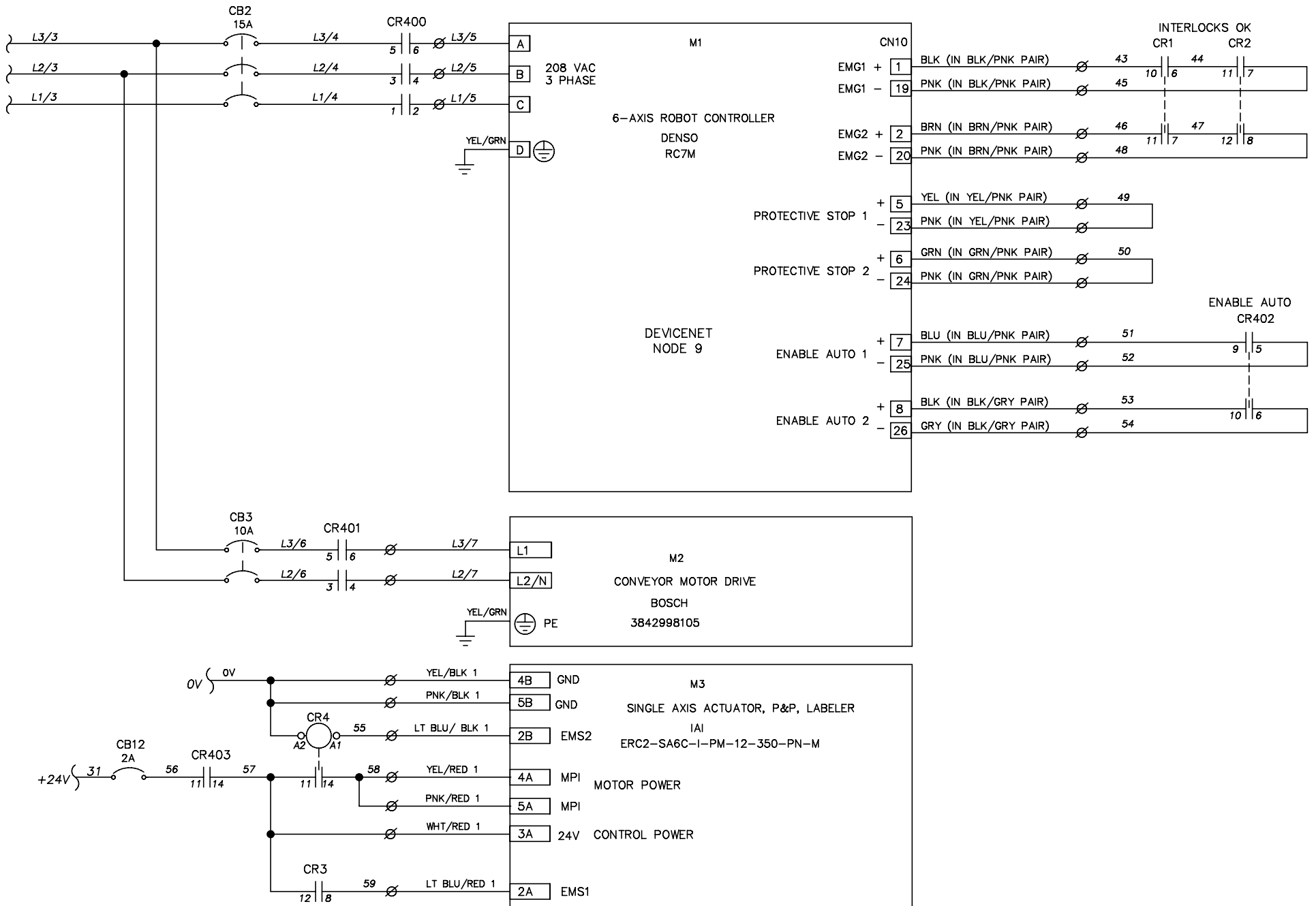

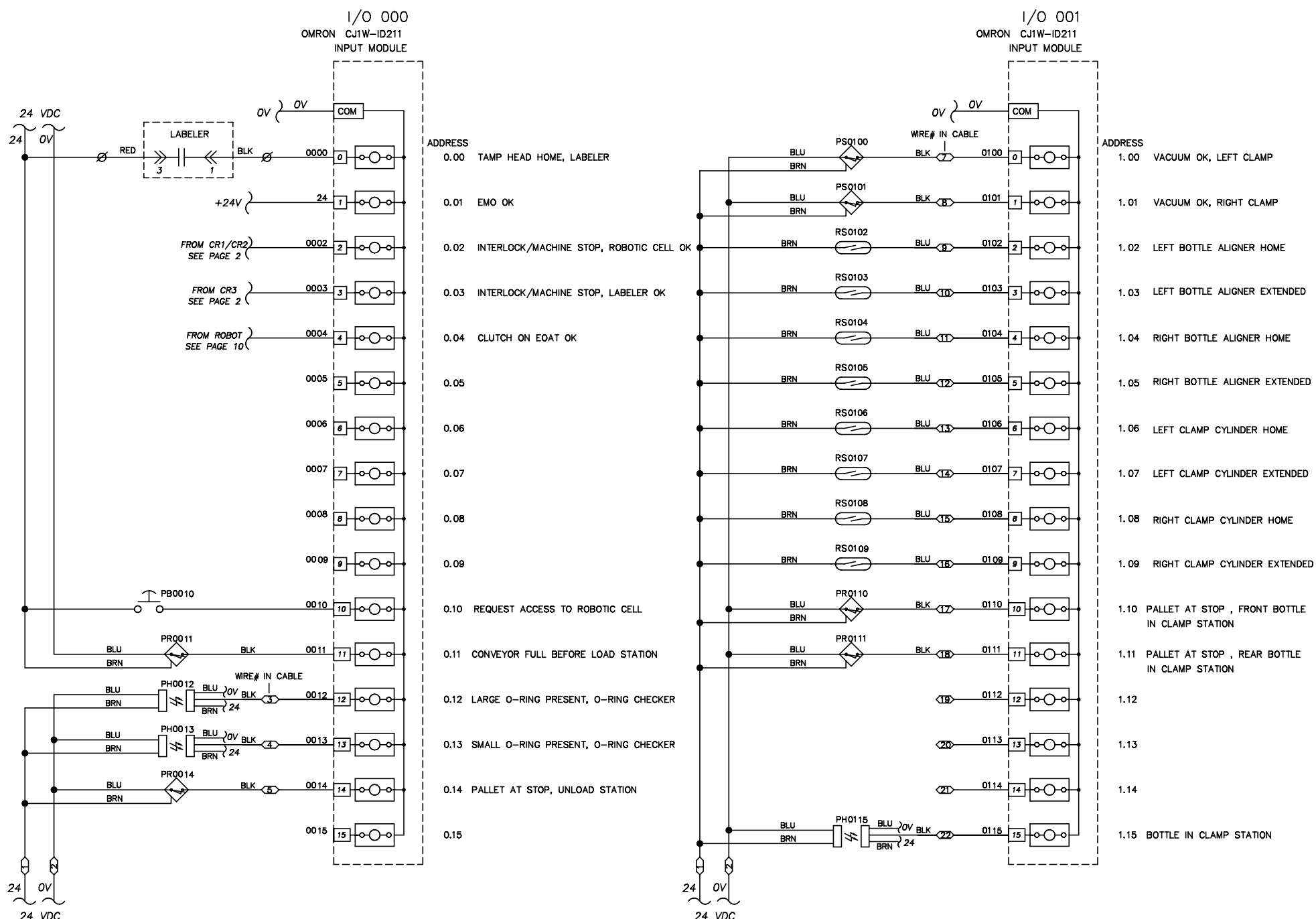

I/O 002
OMRON CJ1W-ID211
INPUT MODULE

I/O 003
OMRON CJ1W-ID211
INPUT MODULE

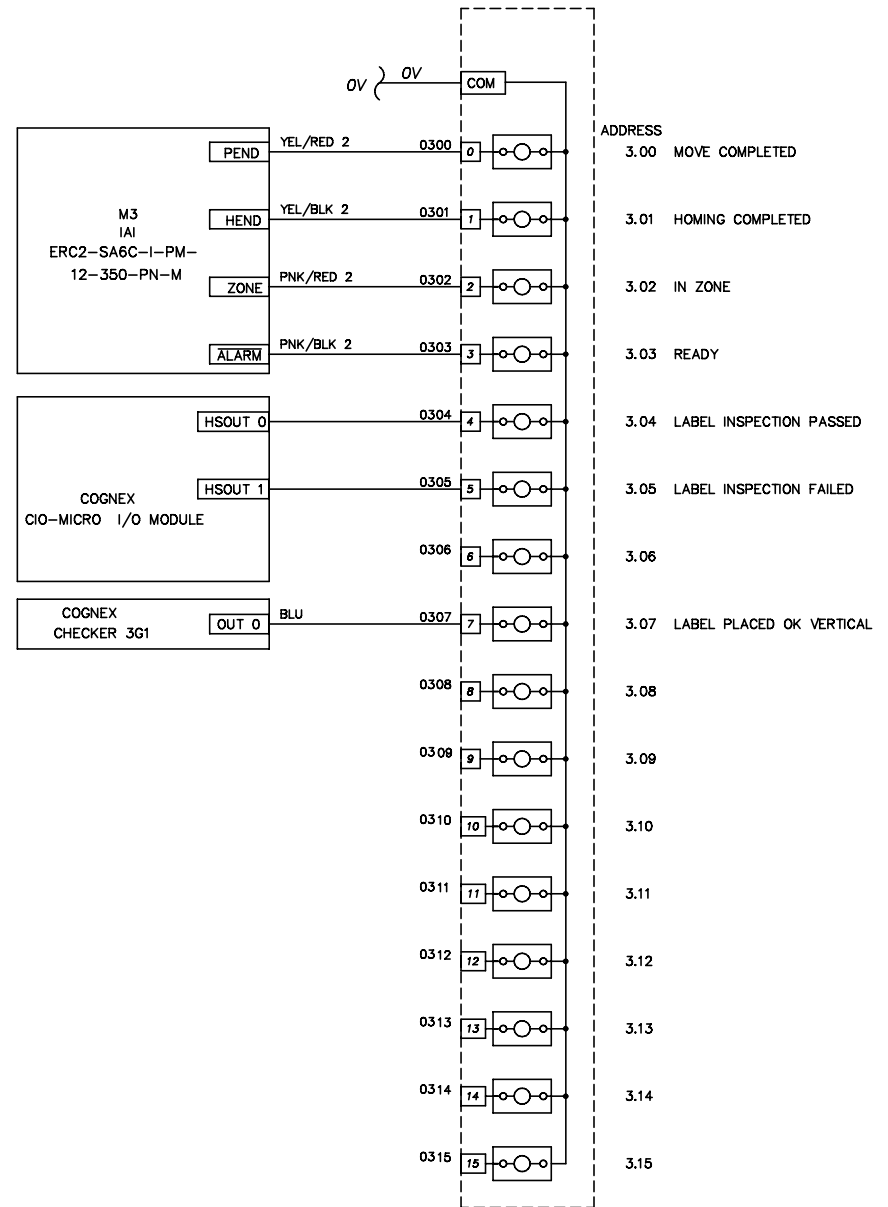
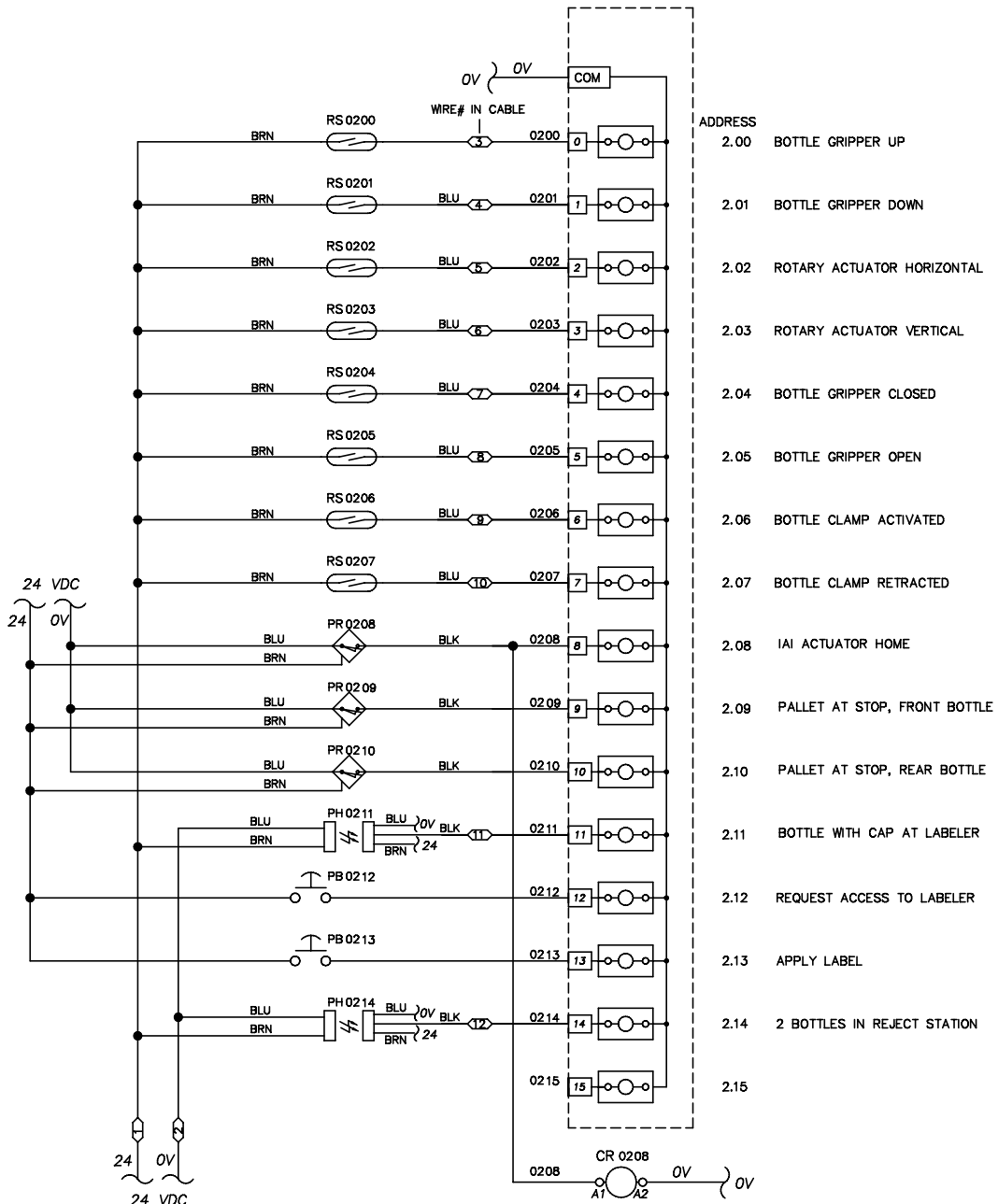

- ADDRESS
- 2.00 BOTTLE GRIPPER UP
 - 2.01 BOTTLE GRIPPER DOWN
 - 2.02 ROTARY ACTUATOR HORIZONTAL
 - 2.03 ROTARY ACTUATOR VERTICAL
 - 2.04 BOTTLE GRIPPER CLOSED
 - 2.05 BOTTLE GRIPPER OPEN
 - 2.06 BOTTLE CLAMP ACTIVATED
 - 2.07 BOTTLE CLAMP RETRACTED
 - 2.08 IAI ACTUATOR HOME
 - 2.09 PALLET AT STOP, FRONT BOTTLE
 - 2.10 PALLET AT STOP, REAR BOTTLE
 - 2.11 BOTTLE WITH CAP AT LABELER
 - 2.12 REQUEST ACCESS TO LABELER
 - 2.13 APPLY LABEL
 - 2.14 2 BOTTLES IN REJECT STATION
 - 2.15

- ADDRESS
- 3.00 MOVE COMPLETED
 - 3.01 HOMING COMPLETED
 - 3.02 IN ZONE
 - 3.03 READY
 - 3.04 LABEL INSPECTION PASSED
 - 3.05 LABEL INSPECTION FAILED
 - 3.06
 - 3.07 LABEL PLACED OK VERTICAL
 - 3.08
 - 3.09
 - 3.10
 - 3.11
 - 3.12
 - 3.13
 - 3.14
 - 3.15